

Note.
 1.Remove all burrs and sharps edge.
 2.Clean oil pollution.

REVISIONS		SIGNATURE AND DATE	
REV	DESCRIPTION	CHK	ENGR

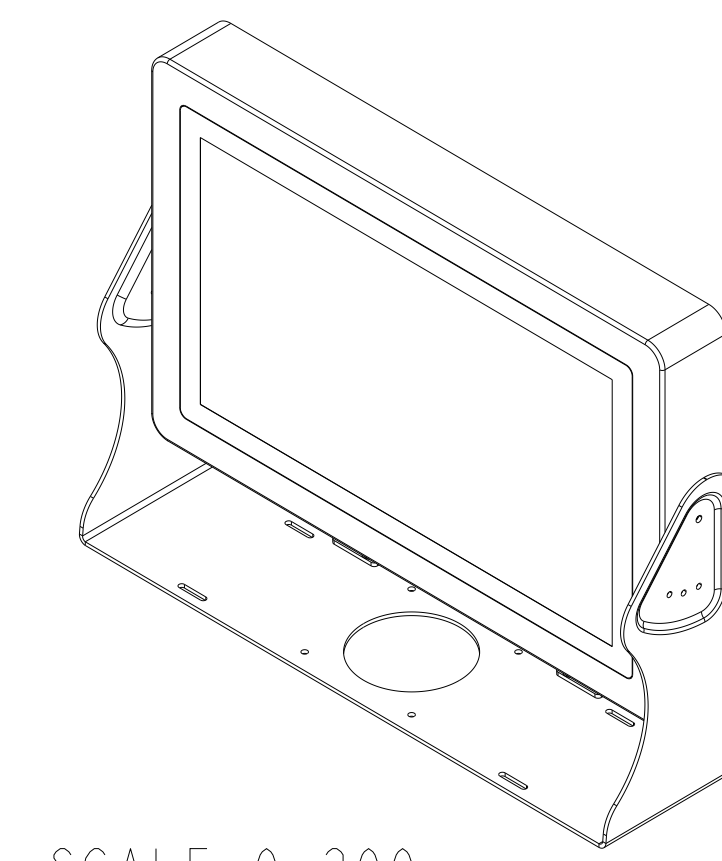

SCALE 0.200

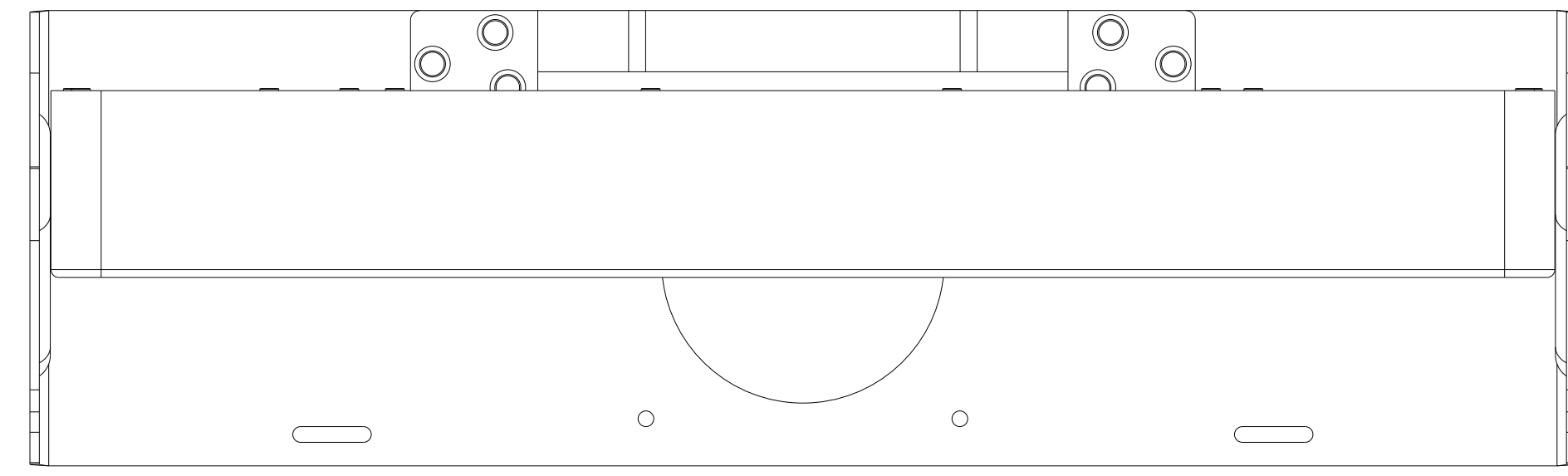
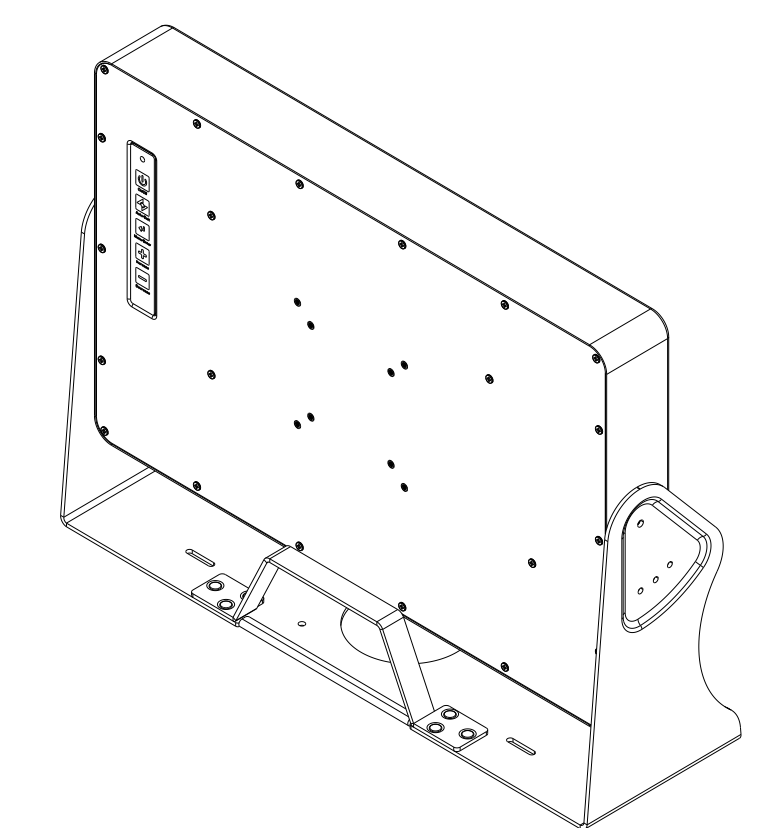

SCALE 0.200

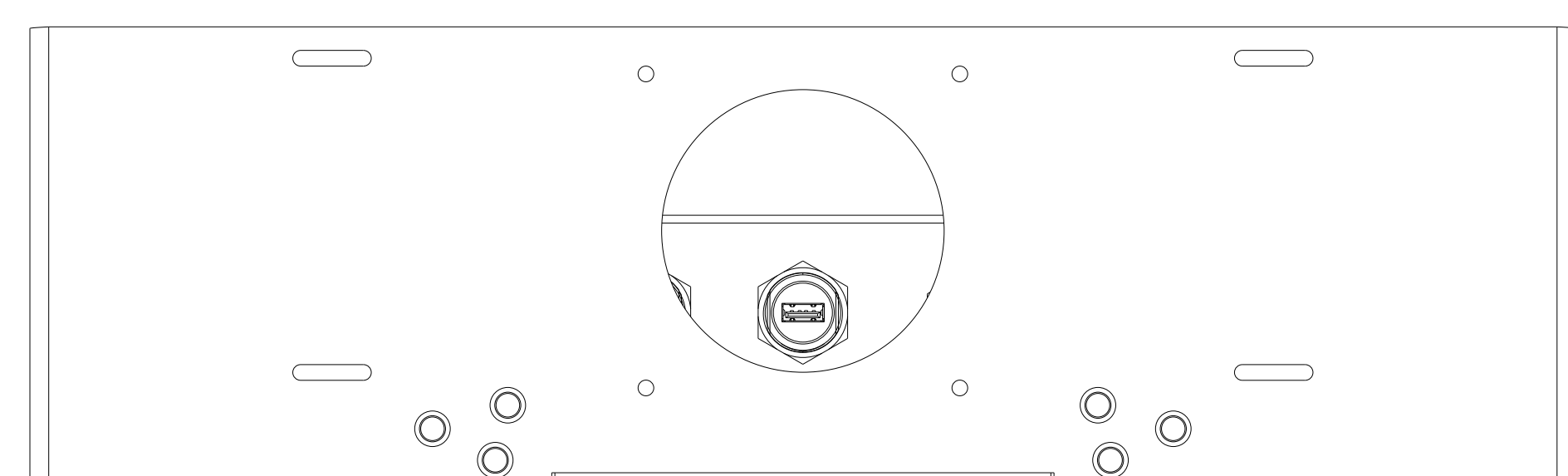
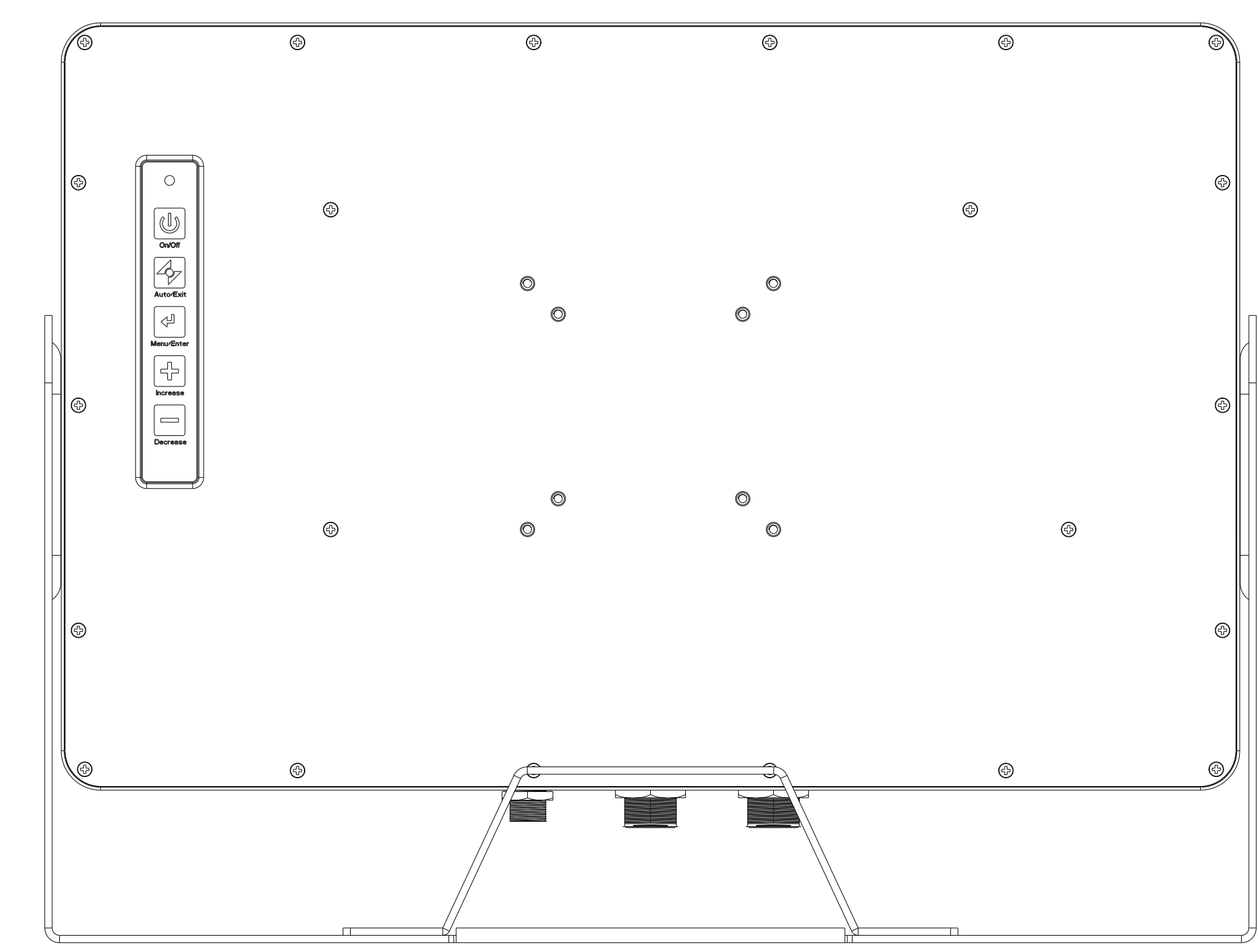
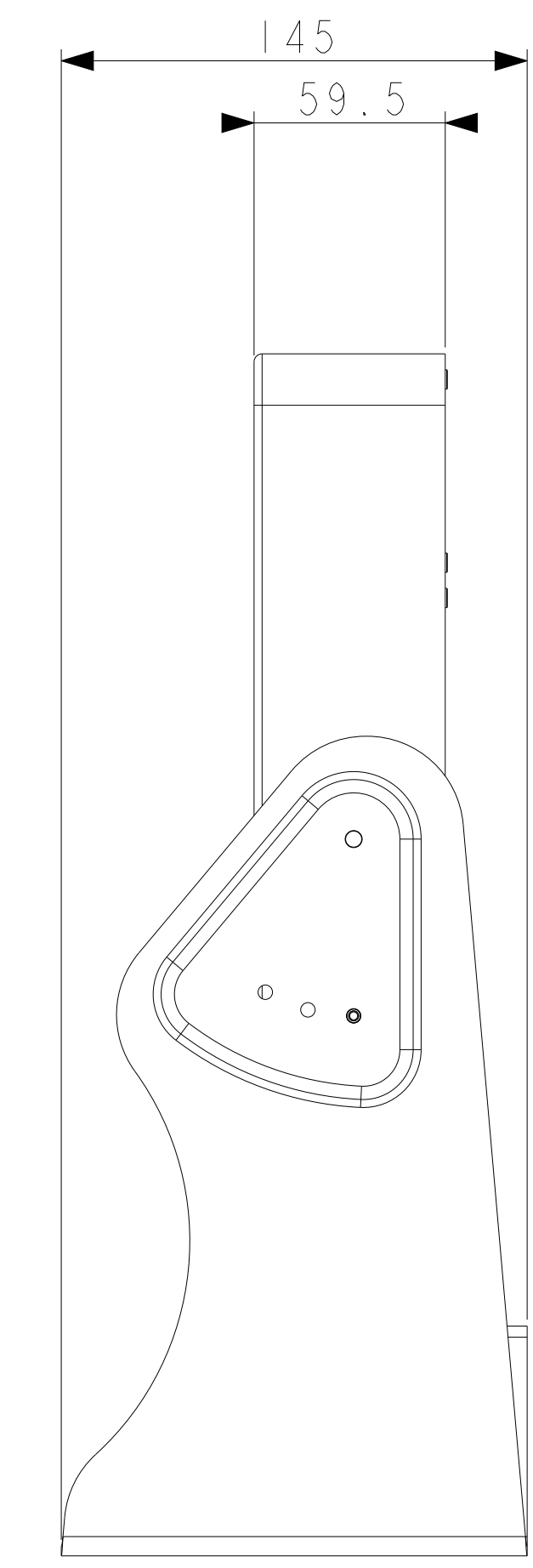
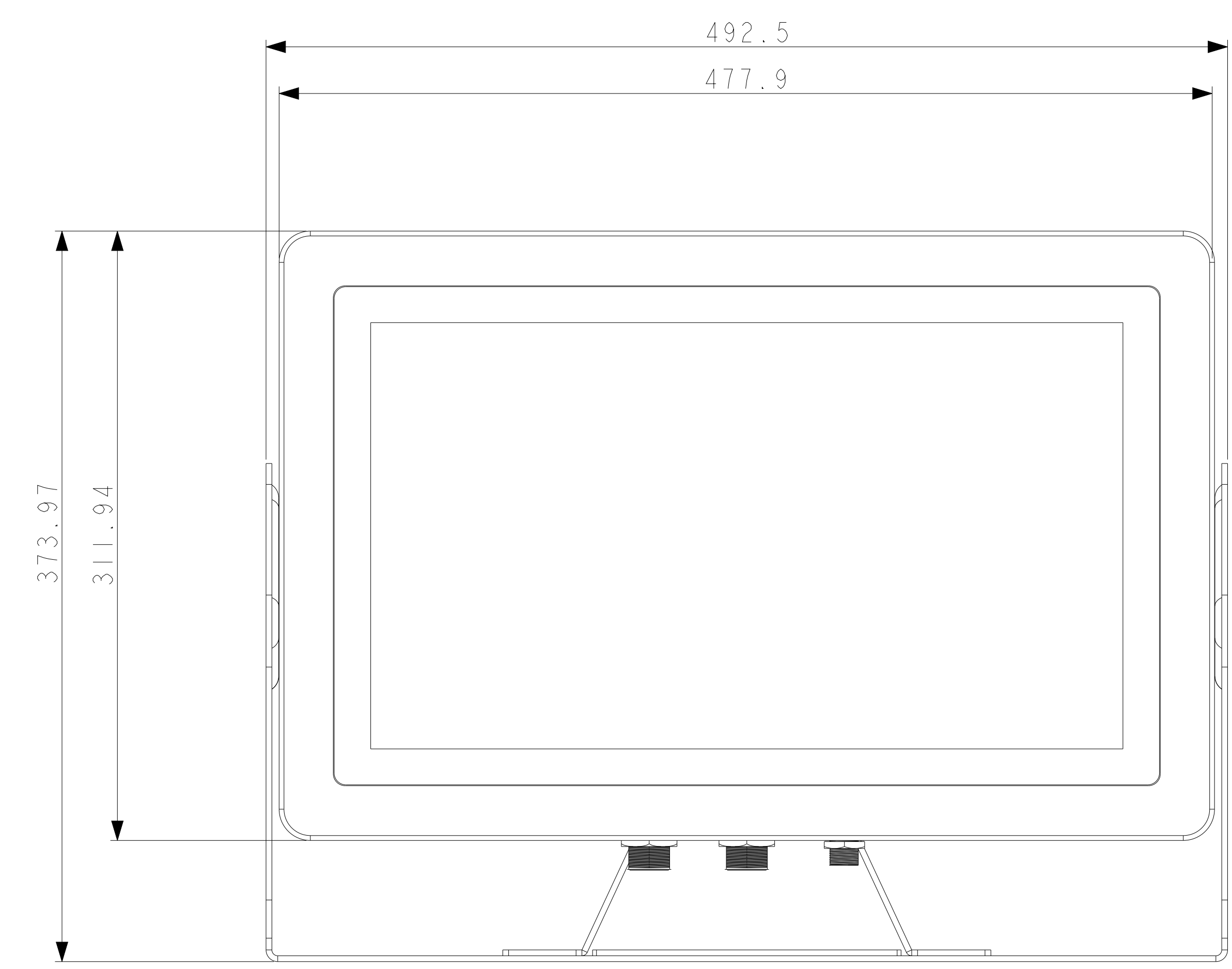
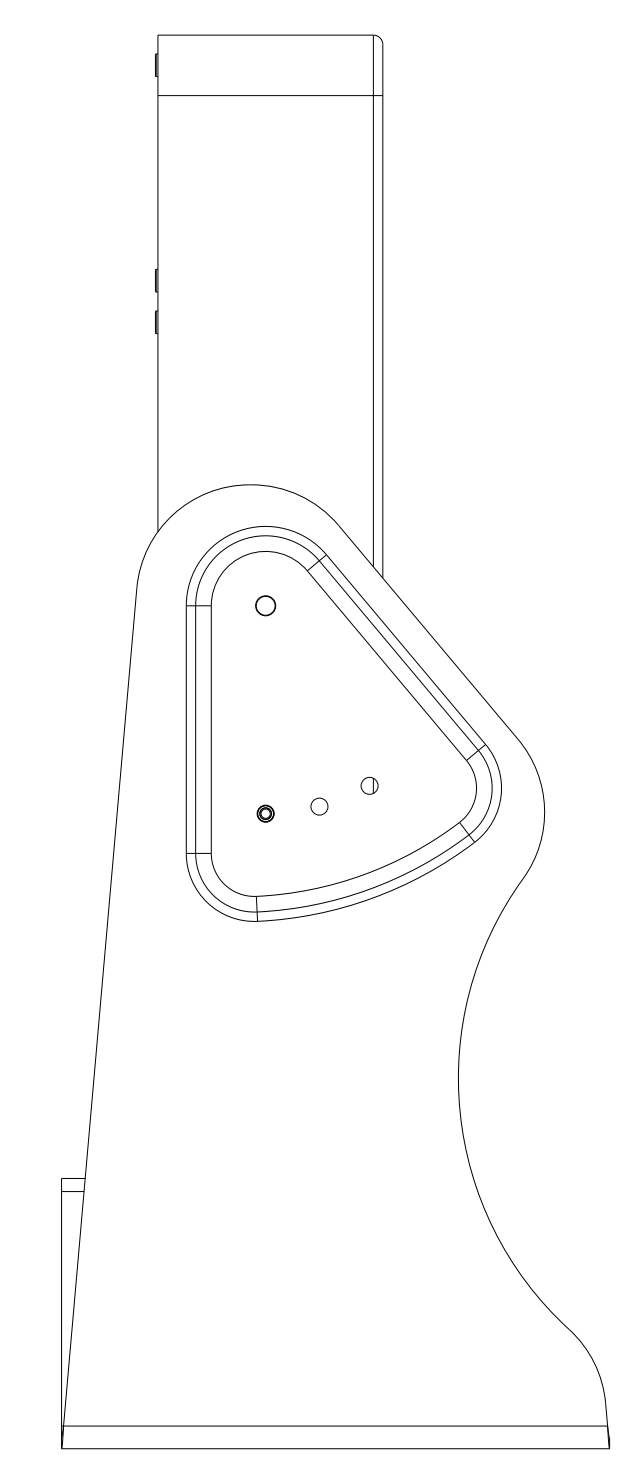

Item	Model name	Part NO.	Part Name	Material	Q'ty	Finish	Remark
8			MEMBRANE-BUTTON		1		
7	TDM-P173M-LPHD	04-000-BPF173-TD1A	LPC-215-Front Bezel	SUS304 1:1.2mm	1		Ø79.1x311.94x59.5mm
6	TDM-P173M-LPHD	03-000-LPF173-TD1A	LPC-215-PANEL-FRAME	SECC 1:1.2mm	1		452x264x40mm
5	TDM-P173M-LPHD/LPC-P173M-2WFS	03-000-LPB173-001A/03-000-LPB173-001A	17.3 Panel Bracket	SECC 1:1.0	2		200x12.4x9mm
4	TDM-P173M-LPHD	03-000-BACR173-TD2A	LPC-215-Back cover	SUS304 1:1.6mm	1		216x308.9x45.6mm
3	TDM-P173M-LPHD	03-000-BACR173-TD1A	Yoke Mount Bracket	SUS304 1:1.3mm	1		Ø92.5x255x145mm
2			Screen M3xL6 1 Head		22		
1					1		

LPC-R215W-LPWS		PART NO.		REMARK	
Range	Tolerance	SCALE	UNIT	SIGNATURE	NAME DATE
201 - Above	±0.30	0.500	mm	DRN BY.	David 2011-11-11
101 - 200	±0.25	TOL.	ANGLE	CHK BY.	
51 - 100	±0.20	MATERIAL:			
31 - 50	±0.15				
30mm Below	±0.10	FINISH:			
Angle	±0.5°	SIZE	A0	SHEET 1 OF 1	DRAWING NO. REV VERSION

ELGENS
 PART NAME:
 LPC-215-Main-Assy